

Pedestals



“BASIC” PEDESTALS

SPECIFICATION SHEET

CARCASS

Carcass and drawer fronts made of 18mm easy to clean scratch-resistant anti-reflective melamine faced chipboard (MFC). Drawer fronts and top finished with 1.5mm ABS impact resistant edges with radius corners.

Finish options:

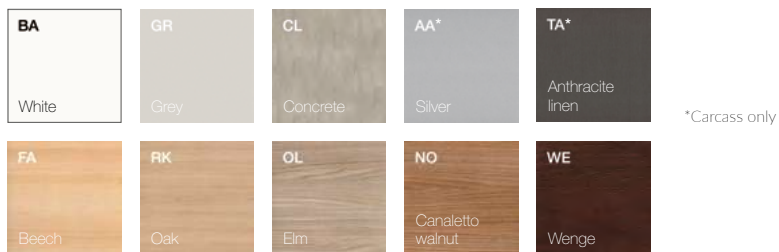

CASTORS

- 580mm high pedestals: four ø50mm twin wheel swivel castors made of black nylon with steel threaded bolt.
- 585mm high pedestals (complete with pen drawer): four embedded ø52mm swivel castors made of black nylon
- 580mm high pedestals: four ø60mm twin wheel swivel castors made of silver nylon with non-marking grey polyurethane rubber. With brake. Steel threaded bolt
- Mobile pedestals fitted with a file drawer include a fifth ø35mm twin wheel castor made of black nylon with steel threaded bolt.

DRAWER BOXES

- Drawer sides are made of grey PVC faced 18mm chipboard, bottom made of matching 3mm grey melamine faced chipboard. As an optional extra drawer boxes can be made from epoxy powder coated 0.7mm steel sheet metal
- File drawers without bottom: pull-out frames for suspension files made from epoxy powder coated 0.8mm steel sheet metal
- File drawers with bottom: frames for suspension files made of folded and welded epoxy powder coated ø5mm steel wire
- Pen drawer supplied with grey plastic moulded tray

RUNNERS

- PVC faced and metal drawer boxes, 80% extension roller runners made of epoxy powder coated moulded sheet metal, with safety stop mechanism. As an optional extra soft close is available on both PVC and metal drawers, offers silent, low impact drawer closing (soft close not available on pen drawer).
- Pen drawer with partial extension roller runners made of epoxy powder coated moulded sheet metal, with safety stop mechanism
- Pull-out frames for suspension files with ball bearing runners made of zinc plated 2mm sheet metal, with safety stop mechanism

HANDLES

Painted ABS handles as standard, epoxy powder coated or chromed metal handles as optional extras.

Look



Silver (J)
White (JB)
Anthracite (JR)

Pop



Silver (P)
Chrome (K)

Zen



Silver (Z)
White (A)
Chrome (Y)
Anthracite (Q)

LOCK

Central locking with two safety folding keys with plastic head. Drawer interlock only single drawer opening at a time.

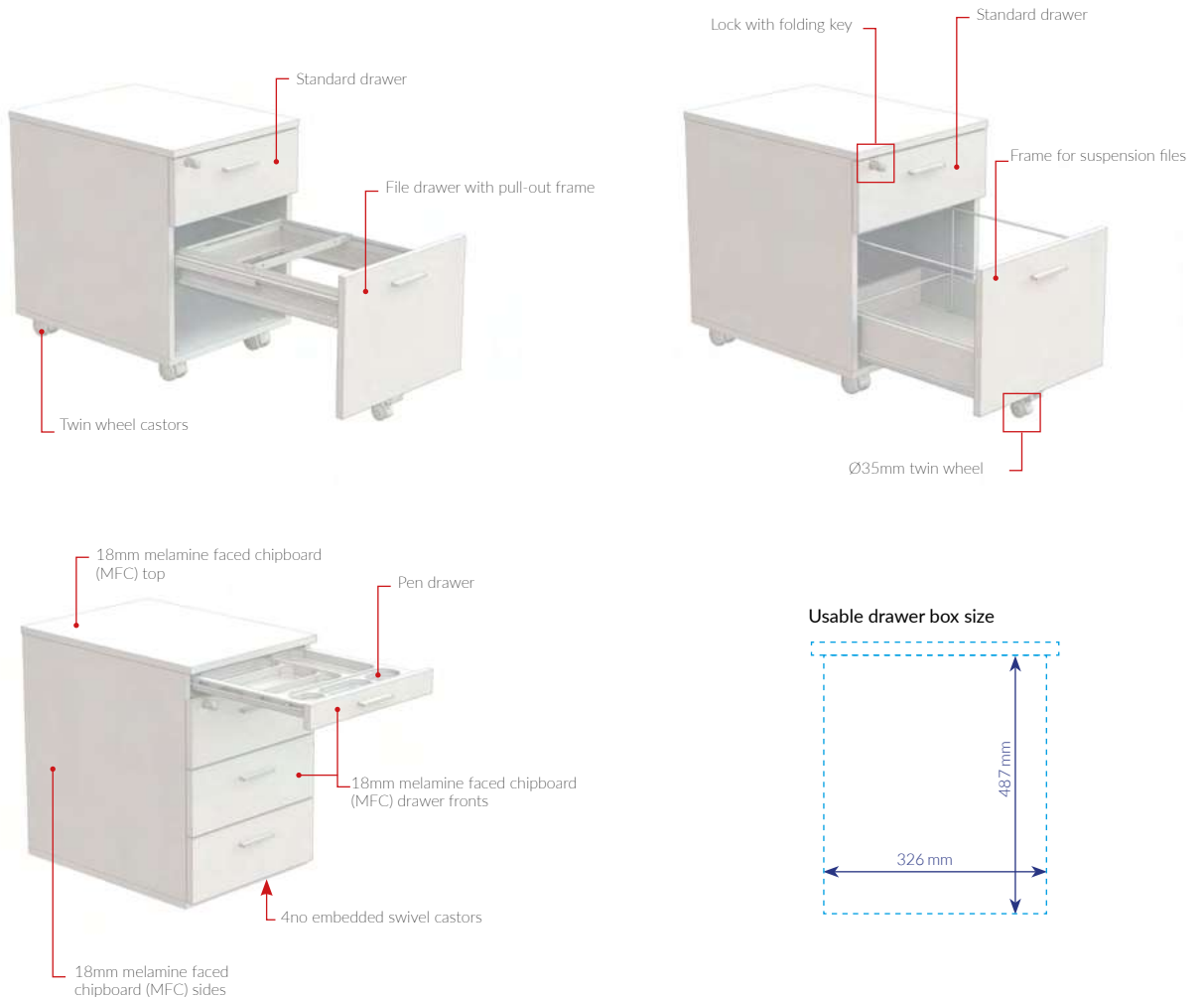

“PLUS” PEDESTALS

SPECIFICATION SHEET

CARCASS

Carcass and drawer fronts made of 18mm easy to clean scratch-resistant anti-reflective melamine faced chipboard (MFC). Drawer fronts and top finished with 1.5mm ABS impact resistant edges with radius corners. All other parts are edged using melamine. Available in melamine or lacquered.

Melamine:

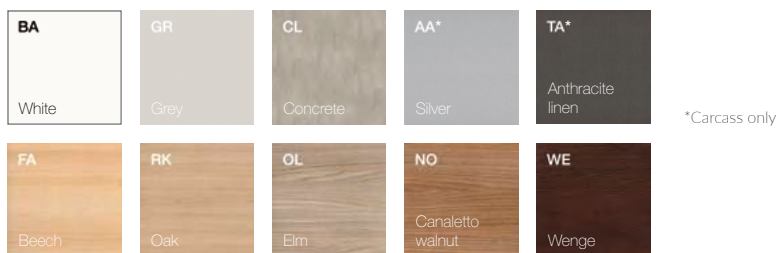

Lacquered:



CASTORS

- 580mm high pedestals: four ø60mm twin wheel swivel castors made of silver nylon with non-marking grey polyurethane rubber. With brake. Steel threaded bolt
- 585mm high pedestals (complete with pen drawer): four embedded ø52mm swivel castors made of black nylon
- Mobile pedestals fitted with a file drawer include a fifth ø35mm twin wheel castor made of black nylon with steel threaded bolt.

DRAWER BOXES

Drawer boxes feature 0.8mm epoxy powder coated steel sheet metal sides and bottom

File drawers: frames for suspension files made from epoxy powder coated steel plates fixed together using nylon joints

RUNNERS

- Metal drawer boxes, 100% extension ball bearing runners made of zinc plated 2mm sheet metal, with safety stop mechanism and soft close for silent, low impact drawer closing (soft close not available on pen drawer).
- Pen drawer with partial extension roller runners made of epoxy powder coated moulded sheet metal, with safety stop mechanism

HANDLES

Epoxy powder coated or chromed metal handles as standard.

Zen



Silver (Z)
White (A)
Chrome (Y)
Anthracite (Q)

Pop



Silver (P)
Chrome (K)

LOCK

Central locking with two safety folding keys with plastic head. Drawer interlock only single drawer opening at a time.

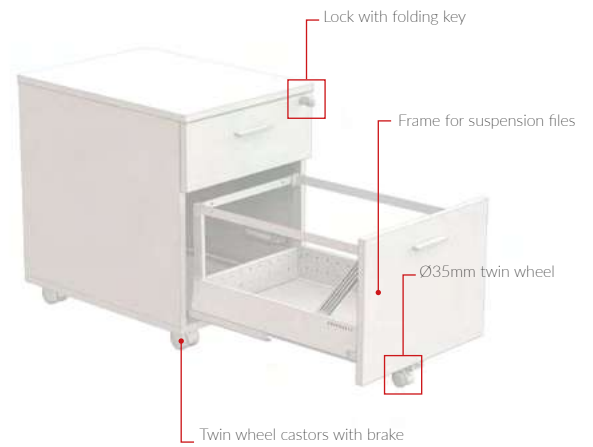
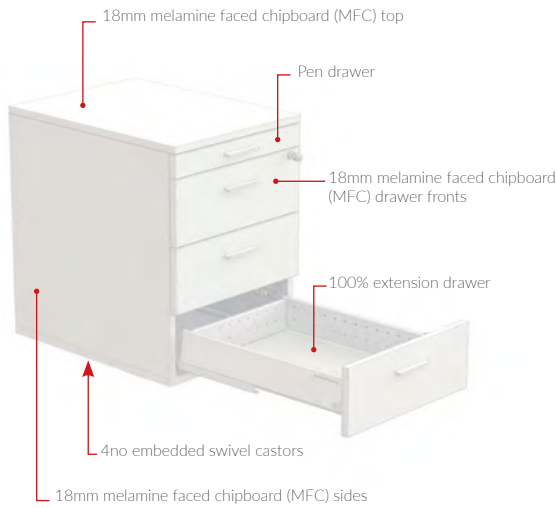

Usable drawer box size

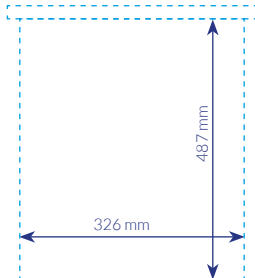

METAL MOBILE PEDESTALS

SPECIFICATION SHEET

CARCASS

Reinforced 1mm steel sheet metal top to sit on it (90 kg max). Carcass and drawer fronts made of 0.8mm steel sheet metal. Structural frame made of 1.5mm steel sheet metal. 5mm radius edges. The full metal surface is epoxy powder coated. Concealed finger pull on both sides of the drawer.

Finish options for sides:



CASTORS

Four ø36mm twin wheel swivel castors made of black nylon with steel threaded bolt.
File drawer supplied with ø25mm fifth castor

DRAWER BOXES

Drawer boxes feature 0.8mm epoxy powder coated steel sheet metal sides and bottom.
File drawers: frames for suspension files made from epoxy powder coated steel plates fixed together using nylon joints.

RUNNERS

Partial extension roller runners made of epoxy powder coated moulded sheet metal, with safety stop mechanism.

LOCK

Central locking with two safety folding keys with plastic head. Drawer interlock only single drawer opening at a time.

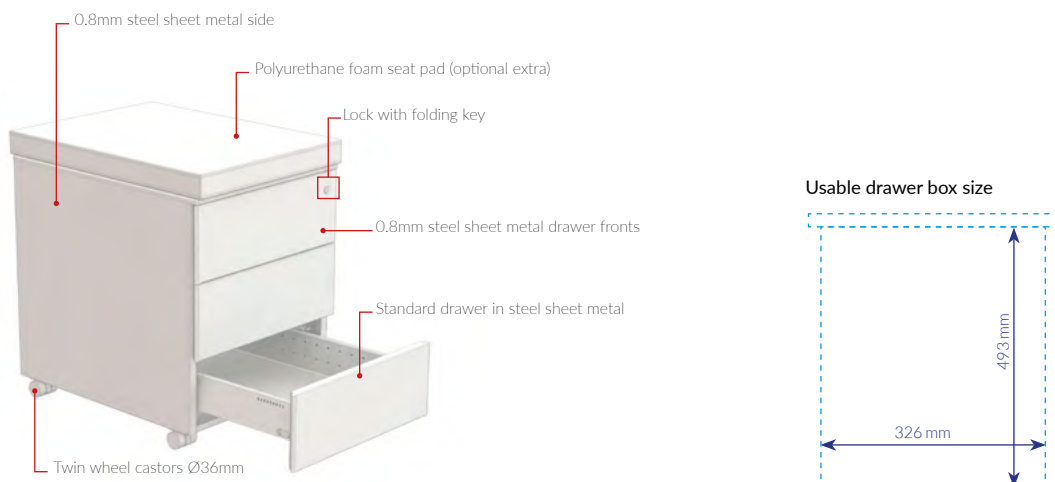

MOBILE COMBINATION UNIT

SPECIFICATION SHEET

CARCASS

Carcass, drawer fronts and door made of 18mm easy to clean scratch-resistant anti-reflective melamine faced chipboard (MFC). Drawer fronts, back, top, bottom and door finished with 1.5mm ABS impact resistant edges with radius corners. The carcass is available in the same finish as drawer fronts and top or in a contrasting finish at no extra cost.

POCKET HINGED DOOR

The pocket door features anti-corrosion treated metal hinges allowing 105° door opening as well as 2mm zinc plated sheet metal ball bearing runners enabling the door to slide inside the CPU section. ABS handle available in a paint finish or chrome effect

Finish options:

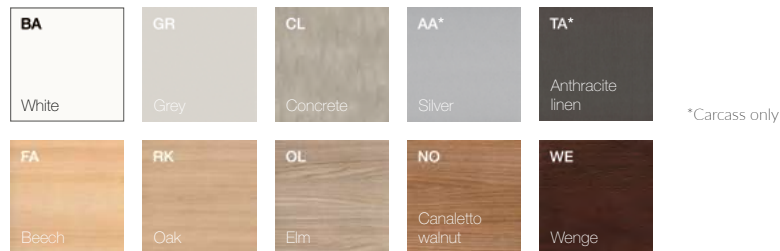

DRAWER BOXES

Drawer sides are made of grey PVC faced 18mm chipboard, bottom made of matching 3mm grey melamine faced chipboard. As an optional extra drawer boxes can be made from epoxy powder coated 0.7mm steel sheet metal. File drawers with bottom: frames for suspension files made of folded and welded epoxy powder coated ø5mm steel wire. Pen drawer supplied with grey plastic moulded tray.

RUNNERS

Partial extension roller runners made of epoxy powder coated moulded sheet metal, with safety stop mechanism. As an optional extra soft close is available on both PVC and metal drawers, offers silent, low impact drawer closing (soft close not available on pen drawer).

LOCK

Central locking with two safety folding keys with plastic head. Drawer interlock only single drawer opening at a time.

CASTORS

Four ø75mm twin wheel swivel castors made of grey polypropylene with non-marking grey polyurethane rubber. Two castors come with brake. Metal plate with steel threaded bolt.

HANDLES

Painted ABS handles as standard, epoxy powder coated or chromed metal handles as optional extras.

Look



Silver (J)
White (JB)
Anthracite (JR)

Pop



Silver (P)
Chrome (K)

Zen



Silver (Z)
White (A)
Chrome (Y)
Anthracite (Q)

CABLE MANAGEMENT

Two ø60mm portholes on the top and one on the bottom complete with chrome effect ABS grommets.

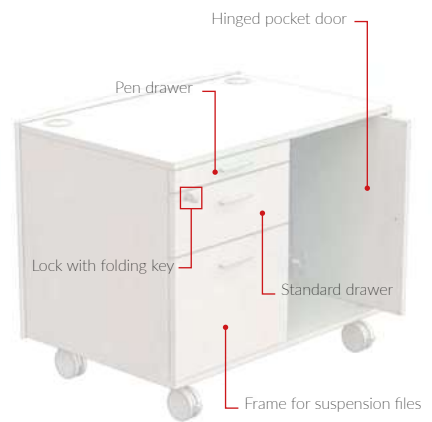

Mobile
combination unit

SPECIFICATION
SHEET

MELAMINE FACED CHIPBOARD (MFC) INTEGRATED DESK HIGH PEDESTAL

X5, X4, X3, Idea+

SPECIFICATION SHEET

CARCASS

Carcass and drawer fronts made of 18mm easy to clean scratch-resistant anti-reflective melamine faced chipboard (MFC). Drawer fronts and top finished with 1.5mm ABS impact resistant edges with radius corners. Integrated desk high pedestals have pre-drilled sides for fitting desktops and desk beams.

CLADDING TOP

Cladding top made of 25mm or 30mm easy to clean scratch-resistant anti-reflective melamine faced chipboard (MFC) finished with 1.5mm or 2mm ABS impact resistant edges with radius corners.

Finish options
for drawer
fronts and
tops:

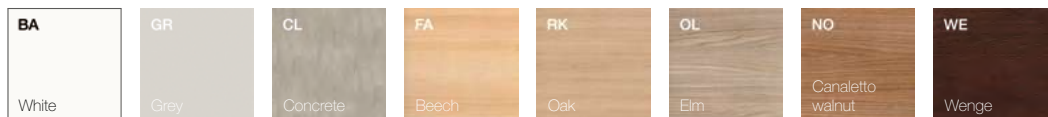

Finish
options for
sides:

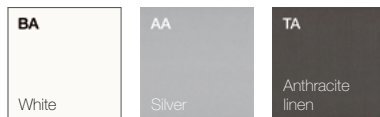

FEET

- Desk high pedestals (except X3-X5): ø50mm black polyethylene feet that are adjustable from the inside of the unit.
- Desk high pedestals (for X3-X5 only): ø38mm 58mm high ABS feet complete with a 0-12mm polyethylene ø35mm leveller.

DRAWER BOXES

- Drawer box sides are made of grey PVC faced 18mm chipboard, bottom made of matching 3mm grey melamine faced chipboard. As an optional extra drawer boxes can be made from epoxy powder coated 0.7mm steel sheet metal
- Pull-out frames for suspension files made from epoxy powder coated 0.8mm steel sheet metal
- Frames for suspension files made of folded and welded epoxy powder coated ø5mm steel wire
- Pen drawer supplied with grey plastic moulded tray.

LOCK

Central locking with two safety folding keys with plastic head. Drawer interlock only single drawer opening at a time.

RUNNERS

- PVC faced and metal drawer boxes, 80% extension roller runners made of epoxy powder coated moulded sheet metal, with safety stop mechanism. As an optional extra soft close is available on both PVC and metal drawers, offers silent, low impact drawer closing (soft close not available on pen drawer).
- Pen drawer with partial extension roller runners made of epoxy powder coated moulded sheet metal, with safety stop mechanism.
- Pull-out frames for suspension files with ball bearing runners made of zinc plated 2mm sheet metal, with safety stop mechanism

HANDLES

Painted ABS handles as standard, epoxy powder coated or chromed metal handles as optional extras.

Look



Silver (J)
White (JB)
Anthracite (JR)

Pop

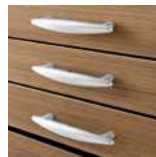

Silver (P)
Chrome (K)

Zen



Silver (Z)
White (A)
Chrome (Y)
Anthracite (Q)

Integrated desk high pedestal

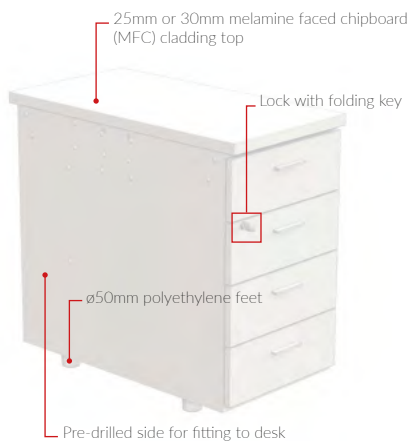

Pair of integrated desk high pedestals for bench desks

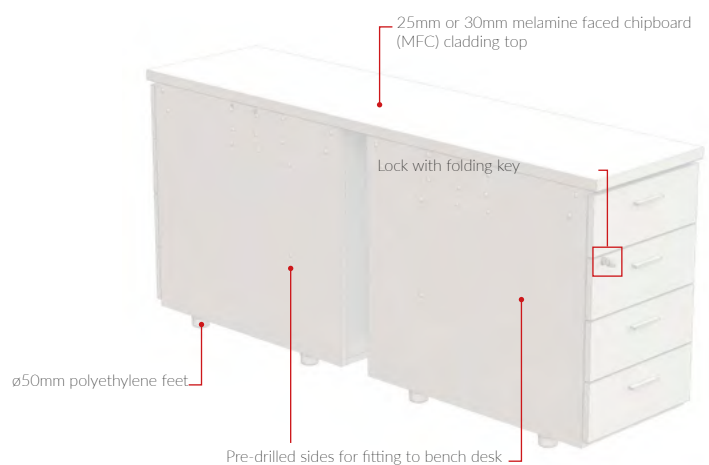

All feet except X3-X5: 27mm high ø50mm polyethylene feet complete with 0-15mm ø25mm polyethylene leveller

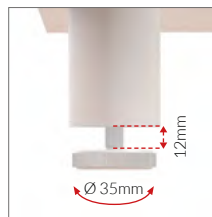

X3-X5 feet: 38mm high ø58mm ABS feet complete with 0-12mm ø35mm polyethylene leveller

Integrated desk high pedestals

SPECIFICATION SHEET

MELAMINE FACED CHIPBOARD (MFC) DESK HIGH PEDESTALS

X3, Idea+

SPECIFICATION SHEET

CARCASS

Carcass and drawer fronts made of 18mm easy to clean scratch-resistant anti-reflective melamine faced chipboard (MFC). Drawer fronts and top finished with 1.5mm ABS impact resistant edges with radius corners. Integrated desk high pedestals have pre-drilled sides for fitting desktops and desk beams.

CLADDING TOP

Desk high top made of 30mm easy to clean scratch-resistant anti-reflective melamine faced chipboard (MFC) finished with 1.5mm or 2mm ABS impact resistant edges with radius corners.

Finish options:

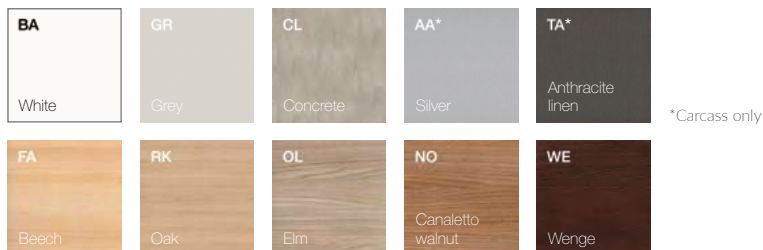

FEET

Support pedestals are supplied with ø38mm painted ABS legs and spacers complete with levelling feet.

DRAWER BOXES

- Drawer box sides are made of grey PVC faced 18mm chipboard, bottom made of matching 3mm grey melamine faced chipboard. As an optional extra drawer boxes can be made from epoxy powder coated 0.7mm steel sheet metal
- Pull-out frames for suspension files made from epoxy powder coated 0.8mm steel sheet metal
- Frames for suspension files made of folded and welded epoxy powder coated ø5mm steel wire
- Pen drawer supplied with grey plastic moulded tray.

RUNNERS

- PVC faced and metal drawer boxes, 80% extension roller runners made of epoxy powder coated moulded sheet metal, with safety stop mechanism. As an optional extra soft close is available on both PVC and metal drawers, offers silent, low impact drawer closing (soft close not available on pen drawer).
- Pen drawer with partial extension roller runners made of epoxy powder coated moulded sheet metal, with safety stop mechanism.
- Pull-out frames for suspension files with ball bearing runners made of zinc plated 2mm sheet metal, with safety stop mechanism

LOCK

Central locking with two safety folding keys with plastic head. Drawer interlock only single drawer opening at a time.

HANDLES

Painted ABS handles as standard, epoxy powder coated or chromed metal handles as optional extras.

Look



Silver (J)
White (JB)
Anthracite (JR)

Pop



Silver (P)
Chrome (K)

Zen



Silver (Z)
White (A)
Chrome (Y)
Anthracite (Q)

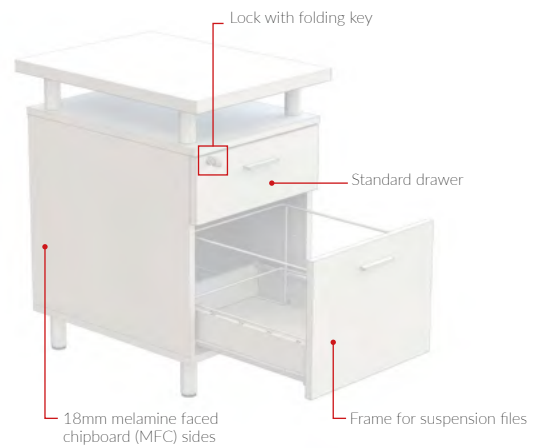
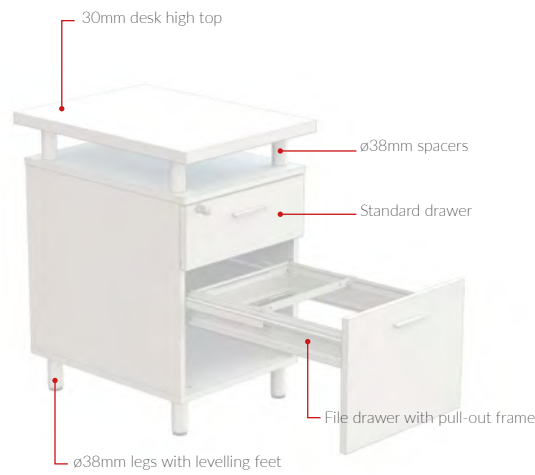

ACCESSORIES

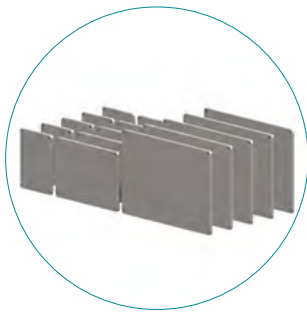

File dividers for use in metal drawers

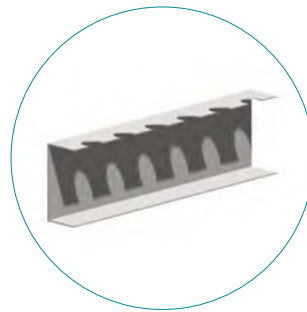

Stamp holder for use in metal drawers



Divider for use in metal drawers

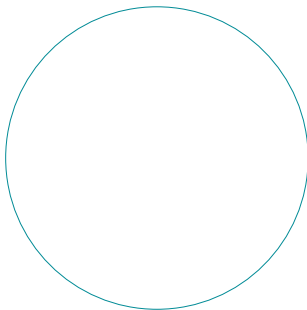

A4 sheet tray for use in metal drawers



Grey Pvc drop-in pen tray



Soft pad made of expanded polyurethane foam upholstered in Trevira CS 100% polyester fabric, the soft pad is secured to the pedestal top using adhesive backed Velcro strips

SUSTAINABILITY & CERTIFICATIONS



MATERIALS AND RECYCLABILITY

Panels used on Storage range are exclusively 100% made by recycled wood and respect low formaldehyde emission (CATAS certification Quality Award Formaldehyde E1). Resins used on panels and melamine paper are SVHC substances free (reported on ECHA list update to 12/01/2017).



STANDARDS

Storage range has passed the following tests, attested by **CATAS** analysis laboratory in San Giovanni al Natisone (UD).

- EN 14073-2:2004, PAR 3.4 Requisiti generali di sicurezza
- EN 14073-3:2004, PAR 5.4 Resistenza dei piani di copertura
- EN 14073-3:2004, PAR 5.5 Stabilità elementi autoportanti
- EN 14074-3:2004, PAR 6.2.1 Resistenza degli elementi estraibili
- EN 14074-3:2004, PAR 6.2.2 Durata degli elementi estraibili
- EN 14074-3:2004, PAR 6.2.3 Apertura con urto degli elementi estraibili
- EN 14074-3:2004, PAR 6.7 Durata a traslazione dei mobili con ruote
- UNI 8601:1984 Flessione dei piani
- UNI 8606:1984 Carico totale massimo
- UNI 9604:1990 Resistenza del fondo dei cassetti



CERTIFICATIONS

Constantly receptive to market requirements, Quadrifoglio Group pay special attention on quality and safety contents in order to provide high products and services. The Company has reached certifications UNI EN ISO 9001/2008, UNI EN ISO 14001/2004 and BS OHSAS 18001/2007 to confirm his policy. Our products are certified and ensured by FSC™ and ECOLOGICAL PANEL.

COMPANY WITH
MANAGEMENT SYSTEM
CERTIFIED BY DNV GL
= ISO 9001 =
= ISO 14001 =
= OHSAS 18001 =



GREEN ENERGY

The Company had installed the photovoltaic system with 4.500 solar panels in a 7.350 m² surface that covers almost entirely the factory. The photovoltaic is able to produce 1Mw of a quiet green energy, that does not harm the environment and is waste-free. With his high production capacity the photovoltaic allows us to reduce emissions in the atmosphere of all those polluting substances and to those that contribute to the greenhouse effects. Consequently, such measures make us save every year 180 tonne of petrol oil, 440 tonne of CO₂, 514kg of sulphur dioxide, 448 kg of nitrogen oxide and 23kg of dust.



TRANSPORT

Pedestals are delivered factory assembled (except handles).

Packaging is reduced in order to decrease volumes. Goods collections are responsibly managed and organised with the aim of optimise transports, reducing atmosphere emissions.