



Plah Ghinn[®]

Design: Stefano Getzel





LUXY

Plah Ghinn®

Design: Stefano Getzel



Open perimeter: that's the underlying theme of this series. This soft seating has no front, no back, no sides. In Plah Ghinn® all sides of the soft seating bases can be built-up, dressed and accessorized with backrests, tables, armrests, tablets, and more.

Un perimetro aperto: questo il tema portante della serie Plah Ghinn®. La morbida seduta non ha fronte, retro o parti laterali. In Plah Ghinn® tutti i lati dei sedili-cuscini possono essere costruiti, rivestiti o accessorizzati con schienali, tavolini, braccioli e ripiani di vario genere.

Offene Begrenzungslinien: dies ist das vorherrschende Thema der Serie Plah Ghinn®. Das weiche Sitzmöbel weist weder Vorderseite, Rückseite noch Seiten auf. Bei Plah Ghinn® können die Seiten der Sitzkissen konstruiert, verkleidet oder als Zubehör genutzt werden mit Rückenlehnen, Tischen, Armlehnen und Bretter jeder Art.

Un perímetro abierto: este el tema primordial de esta serie. Este suave asiento no tiene frente, ni respaldo, ni tampoco laterales. En el Plah Ghinn® se puede construir alrededor de todos los lados base de los asientos, con respaldos revestidos y accesorios tales como mesas, apoyabrazos, mesitas y más.

Un périmètre ouvert: voilà le thème porteur de la série Plah Ghinn®. L'assise souple n'a pas d'avant, d'arrière ou de parties latérales. Dans Plah Ghinn®, tous les côtés des sièges-coussins peuvent être construits, habillés ou équipés d'accessoires comme dossiers, petites tables, accoudoirs et tablettes de divers genres.

Um perímetro aberto: este é o tema portante da série Plah Ghinn®. A cadeira macia não tem parte frontal, traseira ou partes laterais. Em Plah Ghinn® todos os lados dos assentos – almofadas podem ser construídos, revestidos ou enriquecidos de acessórios com apoios para as costas, mesas, apoio para os braços e prateleiras de todos os tipos.

steel

acrylic

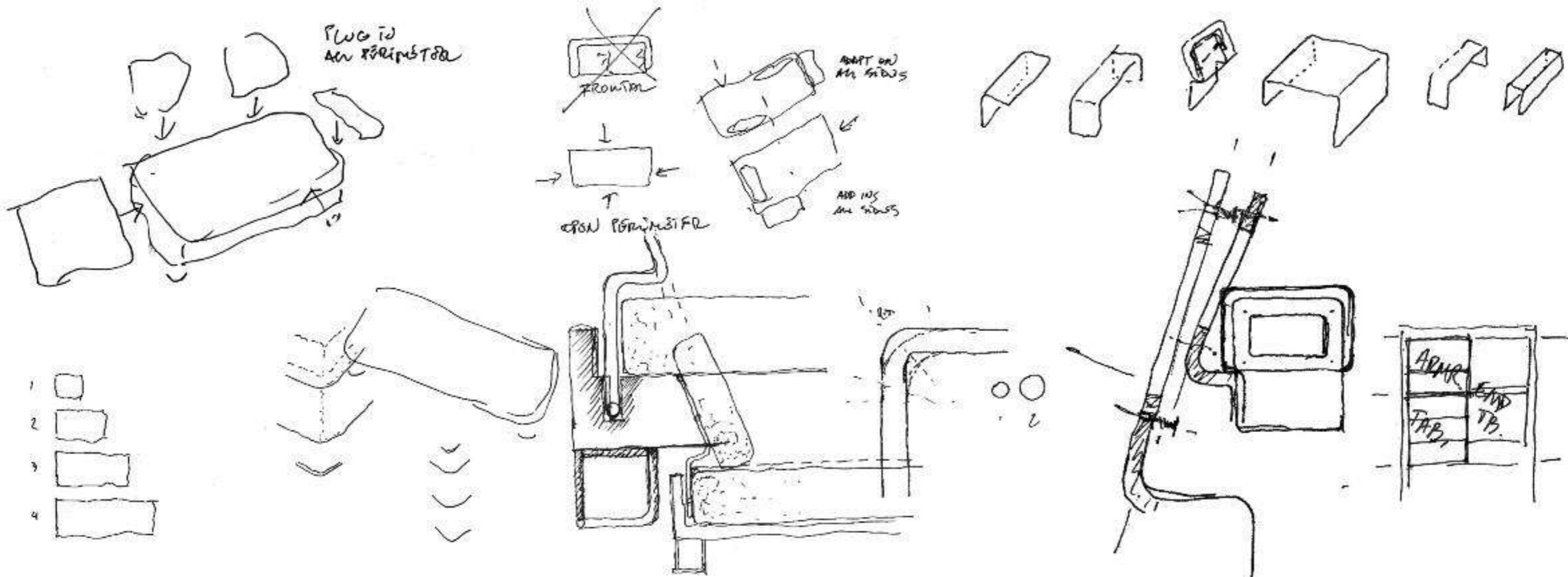

To all the options that an open perimeter will give you, Plah Ghinn® Steel adds aesthetics. Its upholstery allows for dual color or dual material refinement: the horizontal band around the soft seating benches can have a different covering than the seat cushions or backrests, giving you even more choices.

A tutte le possibilità che un perimetro aperto vi può offrire, Plah Ghinn® Steel aggiunge l'estetica. I rivestimenti permettono di abbinare i colori e anche i materiali di rifinitura: la banda orizzontale attorno ai morbidi cuscini delle panche può presentare un rivestimento diverso rispetto a quello dei cuscini di seduta o degli schienali, permettendovi le scelte più svariate.

Zu allen Möglichkeiten die offene Begrenzungslinien bieten fügt sich bei Plah Ghinn® Steel ein ästhetischer Aspekt hinzu. Die Bezüge kombinieren sich hervorragend mit den Farben und den Materialien der Finishes: das horizontale Band entlang der weichen Kissen der Bank kann im Gegensatz zu den Sitzkissen oder den Rückenissen im Bezug variieren und erlaubt somit abwechslungsreiche Alternativen.

A todas las opciones que un perímetro abierto da, el Plah Ghinn® Steel agrega sin lugar a duda una nota de estética. Su tapicería consiente el bicolor o una tapicería de dos tipos de tejido: la banda horizontal alrededor del suave asiento puede ser recubierta con una tapicería diferente de los cojines o apoyabrazos dando así ulteriores alternativas.

A toutes les possibilités qu'un périmètre ouvert peut vous offrir, Plah Ghinn® Steel ajoute l'esthétique. Les habillages permettent d'associer les couleurs et les matériaux de finition: la bande horizontale autour des doux coussins des bancs peut présenter un habillage différent de celui des coussins d'assise ou des dossiers, ce qui vous permet les choix les plus divers.

A todas as possibilidades que podem ser oferecidas por um perímetro aberto, Plah Ghinn® Steel acrescenta a estética. Os revestimentos permitem combinar as cores e também os materiais de acabamento: a banda horizontal ao redor das almofadas macias dos bancos pode apresentar um revestimento diferente com relação àquele das almofadas do assento ou dos apoios para as costas, permitindo as escolhas mais variadas.





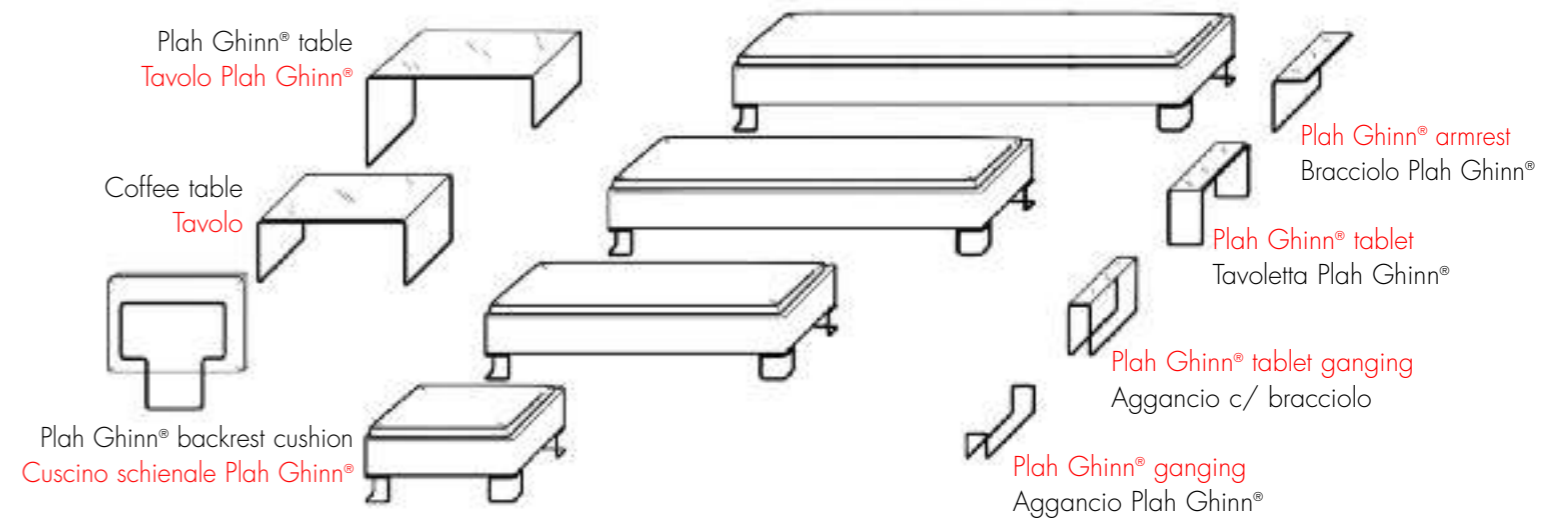





This general theme has been produced in 2 versions: Plah Ghinn® Steel and Plah Ghinn® Acrylic. Plah Ghinn® Steel has tubular steel detailing its structure and can have dual-color upholstery. Plah Ghinn® Acrylic has acrylic structure and a conveniently smaller scale where sensible footprints are important.

Questa nuova concezione di poltrona-divano è prodotta in due versioni: Plah Ghinn® Steel e Plah Ghinn® Acrylic. Plah Ghinn® Steel presenta una struttura in acciaio tubolare con rivestimenti anche bicolore. Plah Ghinn® Acrylic, invece, ha una struttura in materiale acrilico e un criterio di economicità più conveniente dove l'impronta stilistica è comunque importante.

Dieses neue Konzept von Sessel-Sofa wird in zwei Versionen angeboten: Plah Ghinn® Steel und Plah Ghinn® Acrylic. Plah Ghinn® Steel weist eine Stahlrohrstruktur auf mit - auch zweifarbigen - Bezügen. Plah Ghinn® Acrylic, dagegen verfügt über eine Struktur in Acrylic und ist damit eine preiswerte Alternative, bei der ein definierter Stil gleichwohl bedeutend ist.

Este nuevo concepto de poltrona-sofá ha sido creado en dos versiones: Plah Ghinn® Steel y Plah Ghinn® Acrylic. Plah Ghinn® Steel cuenta con detalles de estructura en acero tubular y está disponible con una tapicería bicolor. Plah Ghinn® Acrylic, en cambio, tiene una estructura en material acrílico acompañado de un criterio de economía más convenientemente sin abandonar el toque de estilo de suma importancia.

Cette nouvelle conception de fauteuil-divan est produite en deux versions: Plah Ghinn® Steel et Plah Ghinn® Acrylic. Plah Ghinn® Steel présente une structure en acier tubulaire avec habillage également bicolore. Plah Ghinn® Acrylic, en revanche, a une structure en matière acrylique et un critère d'économicité plus intéressant où l'empreinte stylistique est, quoi qu'il en soit, importante.

Esta nova concepção de poltrona/sofá é produzida em duas versões: Plah Ghinn® Steel e Plah Ghinn® Acrylic. Plah Ghinn® Steel apresenta uma estrutura em aço tubular com revestimentos também bicolores. Por outro lado, Plah Ghinn® Acrylic tem uma estrutura em material acrílico e um critério de economia mais conveniente no qual, todavia, a identidade estilística é importante.

Plah Ghinn®

Design: Stefano Getzel

steel





The Plah Ghinn® Acrylic collection has been created for people who like using their own creativity when designing innovative environments which have to adapt perfectly to different needs. This is indeed a very versatile product also thanks to the modularity of its elements which can be combined, at any time, in a different do-as-you-please setup. Give it a touch of bright colours and modern materials, and Plah Ghinn® Acrylic becomes the unchallenged protagonist in young, unconventional surroundings.

La collezione Plah Ghinn® Acrylic è stata pensata per chi vuole creare ambienti innovativi che valorizzino la propria creatività e si adattino perfettamente alle diverse esigenze. Il prodotto è, infatti, caratterizzato da una grande versatilità, resa semplice e multifunzionale dalla modularità degli elementi, che creano ogni volta un insieme nuovo. A questo si aggiunge la vivacità dei colori e la modernità dei materiali che rendono Plah Ghinn® Acrylic protagonista incontrastato di ambienti giovani e anticonformisti.

Die Kollektion Plah Ghinn® Acrylic wurde entwickelt, um innovative Ambiente zu schaffen, die die eigene Kreativität unterstreichen und sich perfekt an unterschiedliche Anforderungen anpaßt. Das Produkt zeichnet sich durch seine große Vielseitigkeit, aus, ermöglicht durch die einfache und multifunktionale Modularität der Elemente, die jedes Mal ein neues Zusammensein schaffen. Dazu fügt sich die Lebhaftigkeit der Farben und die Modernität der Materialien, die Plah Ghinn® Acrylic zum unbestrittenen Protagonisten in jungen und antikonformistischen Ambienten machen.

Plah Ghinn®

Design: Stefano Getzel

acrylic

La colección Plah Ghinn® Acrylic fue ideada para quienes quieran crear ambientes innovativos que valoricen la propia creatividad y se adapten perfectamente a diversos tipos de exigencias. De hecho, el producto, caracterizado por su gran versatilidad, simplificada y multifuncional gracias a la modularidad de los elementos, que cada vez crean un conjunto diferente. A lo cual se añade la vivacidad de los colores y la modernidad de los materiales que hacen de Plah Ghinn® Acrylic un indiscutible protagonista de ambientes jóvenes y anticonformistas.

La collection Plah Ghinn® Acrylic a été conçue pour ceux qui veulent créer des espaces innovateurs qui valorisent la propre créativité et s'adaptent parfaitement aux diverses exigences. Le produit est en effet caractérisé par une grande polyvalence, rendue simple et multi-fonctionnelle par la modularité des éléments, qui créent à chaque fois un nouvel ensemble. Il faut ajouter à ceci la vivacité des couleurs et la modernité des matériaux qui font de Plah Ghinn® Acrylic le protagoniste incontesté d'espaces jeunes et anticonformistes.

A coleção Plah Ghinn® Acrylic foi projetada para quem quer criar ambientes inovadores que valorizem a própria criatividade e se adaptem perfeitamente às várias necessidades. De fato o produto é caracterizado por uma grande versatilidade, tornada simples e multifuncional pela modularidade dos elementos, que criam cada vez um novo conjunto. Acrescenta-se a isso a vivacidade das cores e a modernidade dos materiais que tornam Plah Ghinn® Acrylic protagonista imbatível de ambientes jovens e anticonformistas.



Redesigning spaces according to how you want to use them and as to how you want them to be used is easy: just go for Plah Ghinn® Acrylic! Cushions go well with backrests, seats match tables and different sized supports, which can be used as working tables when necessary. Comfortable headrests framed in plexiglass which give that sought-after look, peep out from seat backs to offer all-round relaxation in total freedom.

Ridisegnare gli spazi a seconda dell'uso e della funzione che si desidera è molto semplice grazie a Plah Ghinn® Acrylic: i cuscini si adattano agli schienali, i sedili si uniscono a tavolini e appoggi di varie misure, da utilizzare all'occorrenza anche come piano di lavoro. Comodi cuscini fanno capolino dai sedili per offrire un relax a tutto tondo, in piena libertà. Il telaio dei cuscini è in plexiglass per un tocco di ricercatezza che traspare lungo tutti i perimetri.

Räume je nach Nutzen und Funktion neu definieren, das ist mit Plah Ghinn® Acrylic ganz einfach: die Kissen passen sich an die Rückenlehnen an, die Sitze verbinden sich mit den Tischchen und Ablagen in unterschiedlichen Größen, im Bedarfsfall auch als Arbeitsflächen zu nutzen. Bequeme Kissen schauen unter den Sitzen hervor und laden zum vollkommenen Relaxen in völliger Freiheit, ein. Der Rahmen der Kissen ist aus Plexiglas mit einem Hauch von Klasse, der entlang der gesamten Begrenzungslinien durchscheint.



Rediseñar los espacios según su uso y la función deseada es fácil, gracias a que: los cojines se adaptan a los respaldos, los asientos se pueden unir a mesitas y soportes de varias medidas, que pueden ser utilizadas según se ofresca, también como superficies de trabajo. Cómodos cojines apenas se asoman de los asientos para ofrecer un relax completo, en plena libertad. El armazón de los cojines es en plexiglas para darle un toque de sofisticación evidente a lo largo de todo el borde.

Redessiner les espaces selon l'utilisation et la fonction que l'on désire est très simple grâce à Plah Ghinn® Acrylic: les coussins s'adaptent aux dossiers, les sièges s'unissent aux petites tables et aux appuis de différentes mesures, à utiliser aussi, le cas échéant, comme plan de travail. De confortables coussins couronnent les sièges pour offrir un relax ronde bosse, en pleine liberté. Le châssis des coussins est en plexiglas pour une touche recherchée qui transparait le long de tous les périmètres.

Redesenhar os espaços conforme o uso e a função que se deseja é muito simples graças a Plah Ghinn® Acrylic: as almofadas se adaptam aos apoios para as costas, os assentos se unem a mesinhas e apoios com várias medidas, a serem utilizados, quando necessário, até mesmo como plano de trabalho. Almofadas confortáveis surgem dos assentos para oferecer um relax completo, em total liberdade. O chassi das almofadas é em plexiglass como toque de requinte que aparece ao longo de todos os perímetros.



acrylic

acrylic



Armrests, working tables, backrests, cushions: everything plugs in into everything else, on the sides, in the centre, on the back or on the front. It's a revolutionary game of shapes and connections that guarantees total flexibility and at the same time it turns seat restyling into something enjoyable. Set yourself free from the bonds of fixed shapes: Plah Ghinn® padded parts into others and position tables at the corners, or in the centre of your layout. Take your time to reinvent your living space any time you want, any time you need, or even every day, according to how you feel.

Braccioli, ripiani di lavoro, schienali, cuscini: tutto si innesta in ogni dove, ai lati, al centro, sul retro o sul davanti: un gioco di forme e di incastri, che assicura praticità ma rende il tutto anche molto divertente. Liberatevi dalla schiavitù delle forme fisse: agganciate gli imbottiti l'uno all'altro e disponete i tavoli ad angolo o al centro della composizione, per reinventare ogni giorno il vostro spazio vitale, a seconda della necessità o dell'estro del momento.

Armlehnen, Arbeitsflächen, Rückenlehnen: alles fügt sich dort zusammen, wo es sich zusammenfügen muß, an den Seiten, in der Mitte, hinten oder vorne: ein Spiel der Formen und des Zusammensteckens, das Zweckmäßigkeit versichert, aber alles auch sehr unterhaltsam macht. Befreien Sie sich von der Sklaverei der starren Formen: stellen Sie die Möbel zusammen, platzieren Sie Cafétische am Ende oder in der Mitte, um jeden Tag den eigenen Lebensraum, je nach Bedarf oder nach Lust und Laune des Augenblicks, neu zu definieren.

Apoyabrazos, superficies de trabajo, respaldos, cojines: todo se intercala en donde quiera, en los lados, en el centro, por detrás, por delante: un juego de formas y conjuntos, que garantiza lo práctico, volviendo todo el conjunto muy divertido. Libérense de la esclavitud de las formas fijas: aganchen los acolchados unos a otros y arreglen las mesitas en la esquina o al centro de la composición, para reinventar así a diario el propio espacio vital, según la necesidad o el impulso del momento.

Accoudoirs, tablettes de travail, dossiers, coussins: tout s'insère partout, dans les côtés, au centre, sur l'arrière ou sur l'avant: un jeu de formes et d'encastres qui assure la commodité mais rend aussi le tout très amusant. Libérez-vous de l'esclavage des formes fixes: attachez les rembourrages l'un à l'autre et disposez les tables en angle ou au centre de la composition, pour réinventer chaque jour votre espace vital, selon la nécessité ou l'esprit du moment.

Apoios para os braços, planos de trabalho, apoios para as costas, almofadas: tudo se liga com tudo, lateralmente, no centro, posteriormente ou na parte frontal: um jogo de formas e de encaixes, que assegura praticidade mas também torna o conjunto muito divertido. Livre-se da escravidão das formas fixas: junte os estofados um com o outro e disponha as mesas em ângulo ou no centro da composição, para reinventar cada dia o seu espaço vital, em função da necessidade ou da inspiração do momento.



steel

acrylic



10



20



30



40



41

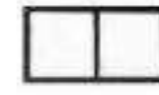

51



61



10 + 50



20 + 50x2



30 + 50x2



40 + 50x3



11



21



31



50



110



100



60



71



81



93



91



92



70



80



90

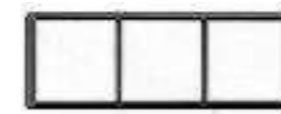



LU-PL4-0411

Concept: Getzel Design Studio

Photography: Renai & Renai (TV)

Print:

Reproductions: E-Graphic (VR)

Printed in Italy: 04/2011



LUXY[®]

LUXY S.R.L. Via Melaro,6 36075 - Alte Ceccato (Vicenza) - ITALY
Tel. +39/0444/696111 Fax +39/0444/694163 E-Mail: luxy@luxy.com

luxy.com

